

Multipurpose Tractors

Regulatory area: EU

TREEMME MC





Comfort: The best workplace



Driver's seat

The driver's seat is at an elevated position to offer better visibility over the work area. The high-quality seat offers superior comfort.

Quiet and comfortable

This model is equipped with Merlo's exclusive patented CS Cushioned Cab with hydraulic suspension that can be disengaged directly by the operator. The low-frequency system reduces vibrations inside the cab and facilitates the absorption of stresses and vibrations transmitted during road transfers and work on uneven terrain.

Exclusive comfort

The driver's seat is at an elevated position to offer better visibility over the work area. The air-suspension seat combined with the powerful air-conditioning system offers superior comfort.

Efficiency: Simpler and smarter



Hydrostatic transmission

The Merlo MCVTronic continuously variable transmission system guarantees maximum efficiency at the highest speeds. The electronic transmission control manages the transition from the "maximum torque" mode to the "maximum efficiency" mode, in response to the user's needs and the operating conditions. The transition takes place in a smooth and continuous manner, ensuring maximum movement uniformity and precision, superior driving comfort, uninterrupted torque transmission and a greater ability to work at reduced speeds for higher performance. Once the desired speed is reached, the diesel engine's rotation speed is reduced, with considerable fuel savings.

Fan Drive

The cooling system is controlled by a hydraulically operated fan that operates according to the temperature. If necessary, the rotation of the fans can be reversed in order to clean the radiator pack of dust and any debris.

Performance: Everything at your fingertips



Easy drive

The four driving wheels are all steered with hydraulic power assistance. Four steering modes are available: on the front wheels, pivot steering, crab steering and on the rear wheels only. The four-wheel drive is permanent.

Hydraulics

The brush-cutter arm terminal equipment is powered by a dedicated hydraulic pump that supplies the tool with a maximum oil flow rate of 150 l/min. A selector switch in the cab allows the hydraulic flow to be directed to the rear PTO (optional), which can handle equipment with a maximum power requirement of up to 40 kW.

Attachments

The machine can be equipped with multiple attachments that can also work simultaneously. The front lift can be combined with category 2 agricultural attachments, powered by a powerful mechanical PTO that can operate attachments such as offset mulchers or mulchers, including forestry types. In winter, the system can be equipped with winter attachments such as ploughs and snow blowers on the front and salt spreaders on the rear lift (optional).

Versatility

The possibility of equipping the machine with various types of attachments, combined with its ability to work off-road thanks to the reinforced chassis and permanent four-wheel drive, offers a versatile and extremely multi-purpose system.

Safety: Not just feelings



Certified cabs

The Merlo cab is ROPS, FOPS and OPS certified thanks to the transparent polycarbonate right side window that protects the operator from any debris thrown up during mowing operations with the brush-cutter arm.

Integrated system

The Treemme brush-cutter arm, perfectly integrated into the machine, does not need to be removed during periods of inactivity as no part protrudes from the outline when it is closed in the road position.



1 - CAB	High driving seat Superior seat comfort 360° visibility Easy access Reduced acoustic impact Approved cab Rops/Fops/Ops Air conditioning
2 - 3-SIDED TOOL SOCKET	Rear implement socket: - Three-point hitch and auxiliary hydraulic outlets - Hydraulic PTO - Hitch
3 - FOUR STEERING MODES	The four-wheel drive wheels are all steered with hydraulic servo assistance. There are four steering modes: on the front wheels, vault corrected, crab steer and optionally on the rear wheels only.



PERFORMANCE AND FEATURES	MM135MC	MM160MC	
Performance			
Unladen weight (kg)	7800	8400	
Powertrain			
Engine	Deutz TCD3.6	Deutz TCD 4.1	
Range/Cylinders (l)	3.6/4	4.1/4	
Engine power (kW/HP)	100/135	115/156	
Anti-pollution technology	Stage IV - SCR + DOC	Stage IV - SCR + DOC	
Maximum speed (km/h)	40	40	
Fuel tank capacity (l)	130	130	
AdBlue tank capacity (l)	18	18	
Hydrostatic transmission	●	●	
Axles	Epicyclic	Epicyclic	
Brakes	Wet discs	Wet discs	
Hydraulic			
Delivery / pressure (L / MIN - BAR)	150/350	150/350	
Hydraulic oil tank capacity (l)	180	180	
Configuration			
Hydropneumatic Suspension CS Merlo	○	○	
Standard tyres	500/70-24	500/70-24	
PTO	●	●	

- not available
- standard
- optional

Dimensions



	MM135MC	MM160MC
A (mm)	5518	5518
B (mm)	725	725
C (mm)	2800	2800
D (mm)	1560	1560
F (mm)	460	460
H (mm)	2470	2470
M (mm)	1500	1500
P (mm)	3080	3070
R (mm)	3950	3950

Technical Details

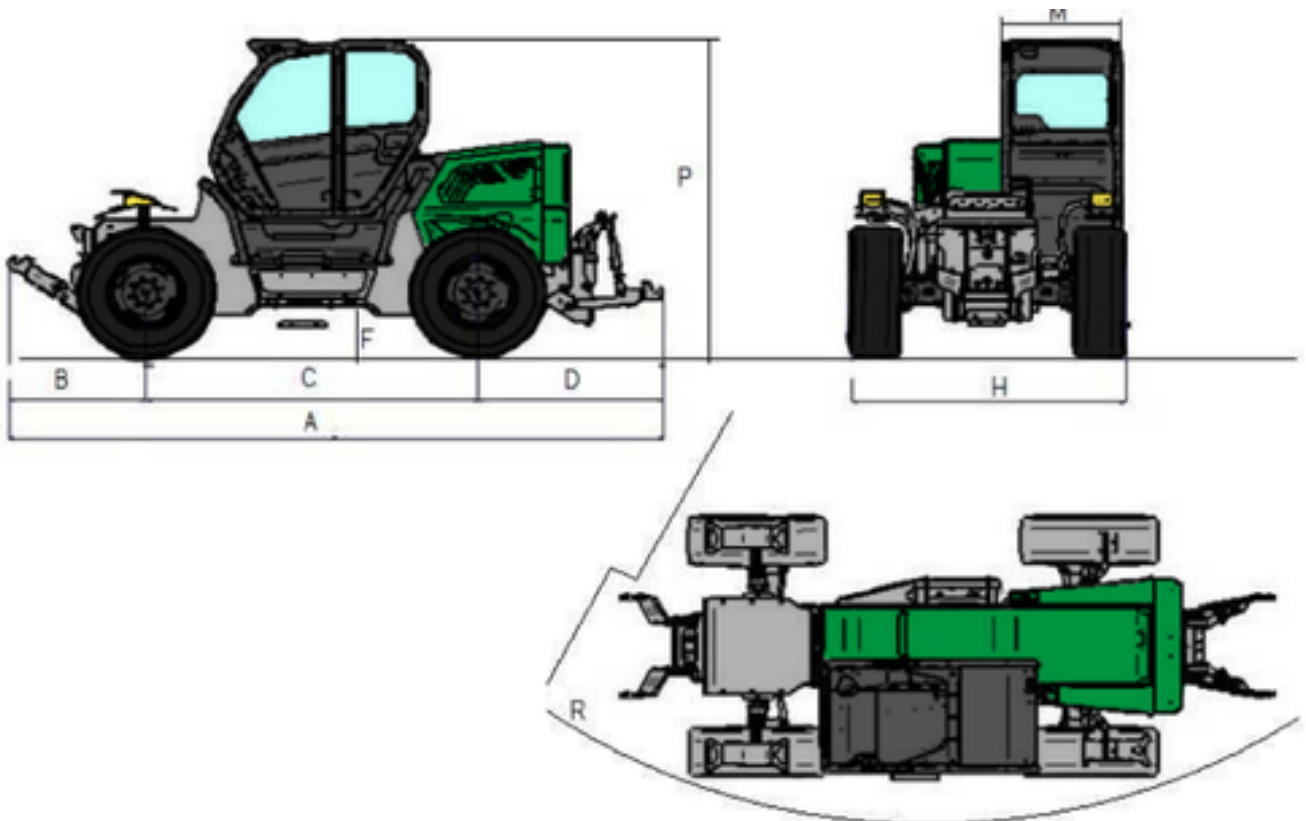

Your Merlo dealer

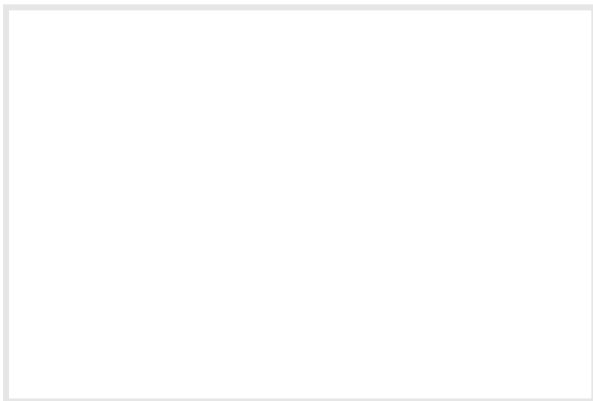

MERLO S.P.A.

Via Nazionale, 9
12010 S. Defendente di Cervasca,
(Cuneo) Italia
Tel. +39 0171 614111

info@merlo.com
www.merlo.com

